

FYRFLY 640 Avionic Thermal Camera

PART# 16386

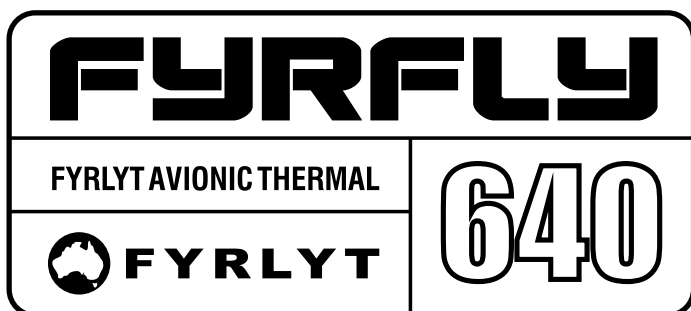

WWW.FYRLYT.COM | MADE IN AUSTRALIA

Index

- 3 Specifications
- 4 Specifications (cont'd)
- 5 Overview & specifications
- 6 Setting focus & palette control
- 7 Cleaning the lens
- 8 Mounting the camera
- 9 Integration with avionics

Document version

This document provides technical information for the FYRLYT FYRFLY 640 thermal camera.

FYRLYT reserves the right to modify the specifications and content of this document as needed. Any subsequent iterations made will be easily identified by the document number located at the top right corner of each page.

SPECIFICATIONS

- Sensor: 640 x 512, 17um, 30mk sensitivity. 8-14um wavelength.
- Lens: 50mm fixed focus lens Germanium. 12.5 deg x 9.4 deg field of view.
- Power input: 12-28 Volts DC, Red = +ve, Black= -ve Ground, White Pallet switch wire.
- Weight: 0.173 kg
- Overall dimensions: 184mm x 109mm x 63mm•Max power draw at 12v = 0.686 Amps
- Analogue output: "Pal"
- 14 palettes

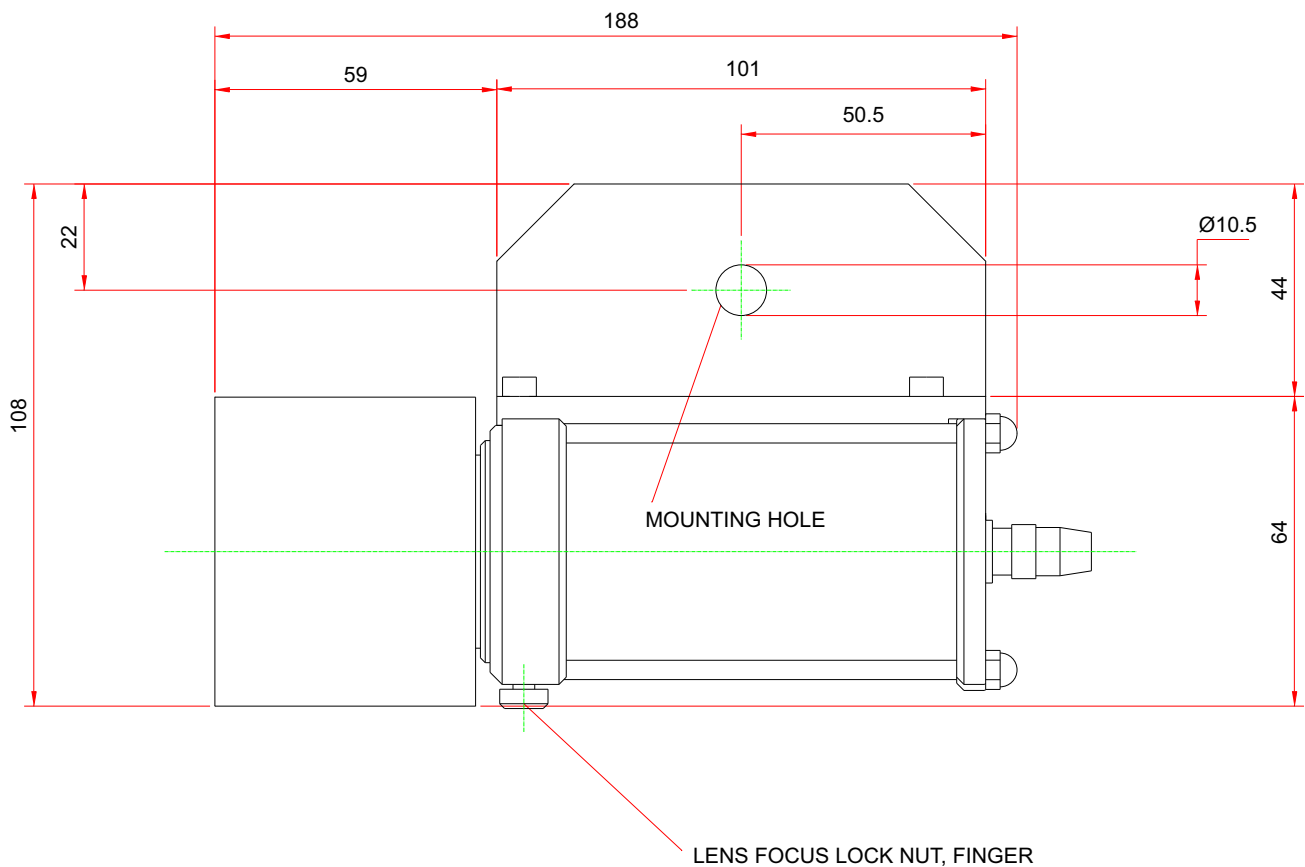

SPECIFICATIONS

- Sensor: 640 x 512, 17um, 30mk sensitivity. 8-14um wavelength.
- Lens: 50mm fixed focus lens Germanium. 12.5 deg x 9.4 deg field of view.
- Power input: 12-28 Volts DC, Red = +ve, Black= -ve Ground, White Pallete switch wire.
- Weight: 0.173 kg
- Overall dimensions: 184mm x 109mm x 63mm•Max power draw at 12v = 0.686 Amps
- Analogue output: "Pal"
- 14 palettes

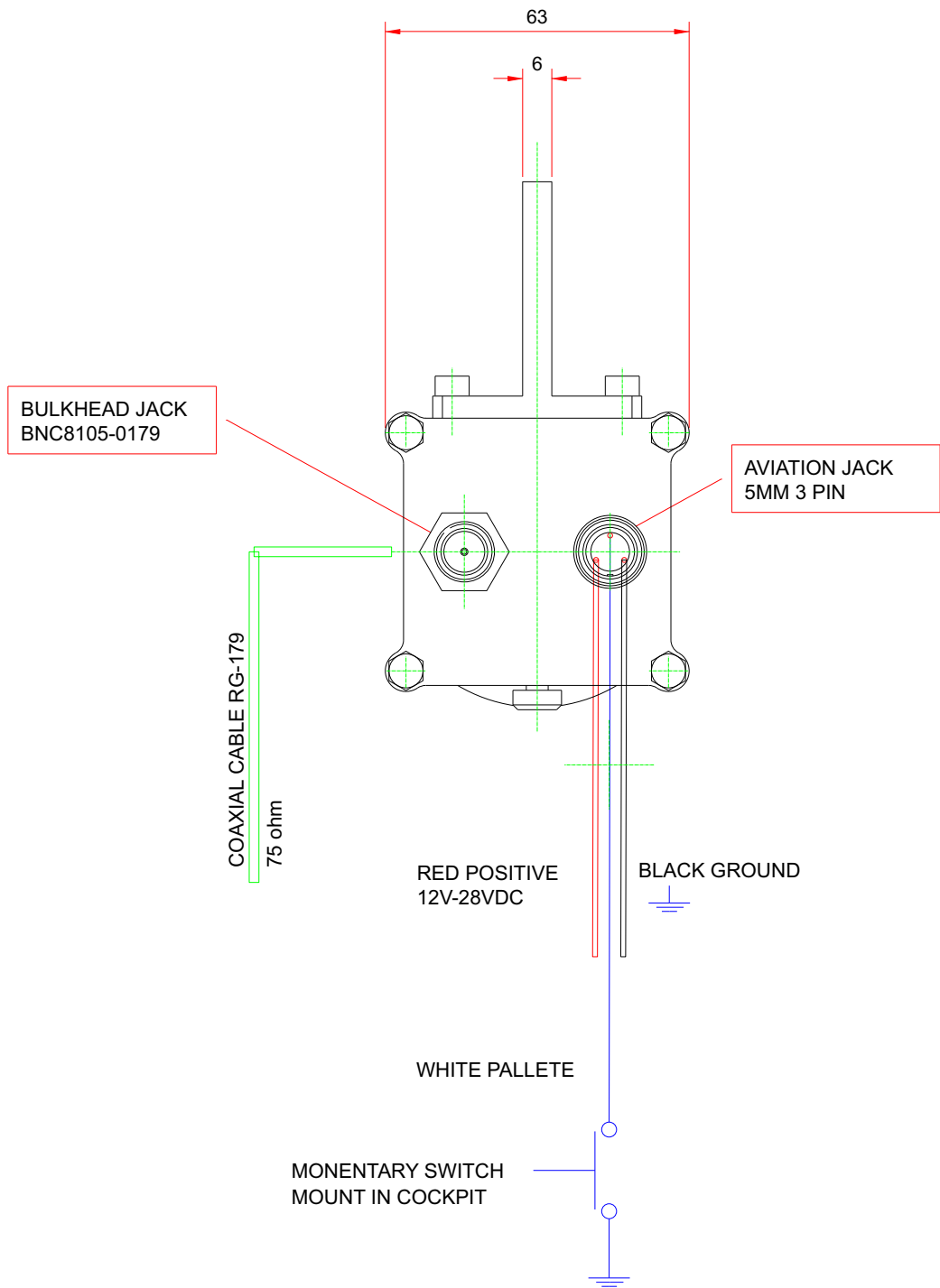

FYRLYT FYRFLY 640 THERMAL CAMERA INTRODUCTION

The FYRFLY 640 is a robust and versatile thermal imaging solution engineered to meet the demanding requirements of the aviation industry. Its compact design, ease of integration, and high-performance imaging capabilities make it a valuable asset for a wide range of airborne applications. The FYRFLY 640 offers aviation professionals a valuable tool for enhancing safety and operational effectiveness in a variety of applications, including:

- Aerial Fire Fighting
- Enhanced Night Vision: Improved situational awareness during nighttime operations, enabling safer navigation and obstacle avoidance.
- Search and Rescue: Rapidly locate individuals or objects in challenging terrain or low-visibility conditions.
- Wildlife Monitoring: Observe and track wildlife populations for conservation and management purposes.
- Surveillance and Patrol: Support law enforcement and security operations with enhanced observation capabilities.
- Infrastructure Inspection: Identify potential issues with power lines, pipelines, and other critical infrastructure.

KEY FEATURES & CAPABILITIES

High-Resolution Thermal Imaging: Utilising a 640 x 512 pixel uncooled microbolometer sensor with a 17 μ m pixel pitch, the FYRFLY 640 delivers detailed thermal imagery for superior object detection and recognition. A thermal sensitivity of 30mK ensures clear differentiation of subtle temperature variations.

Germanium Optics: The camera is equipped with a high-quality 50mm fixed focus Germanium lens, providing a 12.5° x 9.4° field of view optimized for aerial observation. Germanium's excellent transmission in the 8-14 μ m waveband ensures optimal performance in various atmospheric conditions.

Versatile Integration: The FYRFLY 640 outputs a standard analog PAL video signal, via 75 ohm RG-179 coaxial cable. This facilitates compatibility with a wide range of existing aircraft displays.

Ruggedised Construction: The camera's housing is constructed from machined hard anodised aluminium to withstand the rigours of airborne operation, including vibration, shock, and temperature extremes. This ensures reliable performance and longevity in challenging environments.

Lightweight and Compact: With a weight of only 0.173 kg and compact dimensions (184mm x 109mm x 63mm), the FYRFLY 640 minimizes impact on aircraft weight and balance. This allows for flexible mounting options with minimal impact on aircraft performance.

Efficient Power Consumption: Operating on a 12-28 Volt DC power supply, the FYRFLY 640 has a maximum power draw of 0.686 Amps at 12V, ensuring minimal burden on the aircraft's

SETTING MECHANICAL FOCUS

After installing and powering up the FYRFLY 640 you need to set the mechanical focus. The mechanical focus should be set during the mid-afternoon on a day with low humidity when thermal profiles are conducive to sharp imaging.

HOW TO ADJUST FOCUS

Back off brass screw at bottom of camera approximately $\frac{1}{2}$ to 1 turn... point the camera at a sharp edge like a fence post or edge of a wall at your nominal search distance and turn lens +/- $\frac{1}{2}$ a turn until image sharpens. Do not completely unscrew lens....Tighten brass screw finger tight only when focus is set. Focus the camera at the range you require the best images.... As a starting point 600m-1000m is generally acceptable. Quality of image produced varies with thermal conditions. High humidity will negatively affect thermal image quality as will long periods at a fixed ambient temperature when all items ultimately have time to cool to the same temperature which will reduce image contrast.

PLEASE NOTE

- Replace lens cap after use.
- Water and dust sitting on the lens will negatively affect image quality.
- High humidity will affect image quality.
- Poor focus will affect image quality.

PALETTE CONTROL

Palette control is managed by grounding the white wire via a momentary switch, 14 palettes are available and can be toggled through sequentially by a single pulse of the momentary switch.

COLOUR PALETTES

WHITE | BLACK | FUSION | RAINBOW | GOLDBOW | SUNBOW | IRONBOW | SEPIA | JADE | GLOWBOW | ICEFIRE | OILPAINT | POMEGRANATE | EMERALD.

CARE & CLEANING THE THERMAL CAMERA LENS

- Keep the lens covered when not in use
- **DO NOT POINT THE CAMERA STRAIGHT INTO THE SUN!**
- Remove dust. Gently blow or dust the lens with a lens cleaning brush to remove any loose dirt or debris.
- Prepare the cleaning solution. Mix 96% isopropyl alcohol with distilled water in a 1:1 ratio. You can also use a commercial lens cleaner that contains at least 30% isopropyl alcohol.
- Dampen a cotton ball or lens tissue with the cleaning solution. Do not soak the cotton ball or tissue, as this could cause the lens to fog up. (do not use a common sanitary tissue these can scratch the lens)
- Wipe the lens in a circular motion. Start from the centre of the lens and work your way out. Wipe the lens gently, as applying too much pressure could scratch the surface.
- Dry the lens with a clean, dry cotton ball or lens tissue.
- Inspect the lens. Make sure that the lens is clean and free of any streaks or smudges.
- Do not use any harsh chemicals or solvents to clean the lens.
- Do not use paper towels or tissues to clean the lens, as these materials can leave behind fibres.
- If the lens is heavily soiled, you may need to repeat the cleaning process several times.
- Do not touch the lens with your fingers, as this can leave behind oils and fingerprints.
- Do not use a lens cleaning solution that contains ammonia or acetone, **DO NOT USE WINDEX** or household glass cleaners under any circumstances. The lens is not glass it is germanium and requires careful cleaning.



ACETONE



AMMONIA
'WINDEX'



HOUSEHOLD
CLEANERS



SANITARY TISSUE OR
NON-SPECIFIC CLOTH

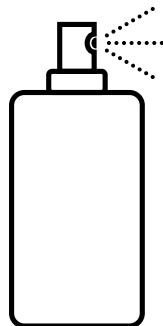

CLEANING SOLUTION

Mix 96% isopropyl alcohol with distilled water in a 1:1 ratio.

You can also use a commercial lens cleaner that contains at least 30% isopropyl alcohol.

MOUNTING THE FYRFLY 640 THERMAL CAMERA

Mounting is to be undertaken by suitably qualified personnel and certified.

The FYRLYT FYRFLY 640 thermal imager is designed for versatile integration with various aircraft platforms.

Mounting considerations must account for optimal field of view, minimising aerodynamic impact, and ensuring structural integrity. Recommended installation practice involves utilizing a vibration-isolated mount to mitigate potential damage from airframe vibrations.

Mount location should be selected to avoid interference with existing aircraft systems and to provide a clear line of sight for the camera, free from obstructions. Aerodynamic effects of the installation must be assessed to ensure minimal disturbance to airflow and aircraft handling characteristics.

All mounting hardware and procedures must be in accordance with relevant aviation regulations and the aircraft's structural limitations.

Post-installation testing is required to verify camera functionality, image stability, and structural integrity under operational conditions.



FYRLYT FYRFLY 640 installation - Air Tractor

FYRFLY AVIONICS DISPLAY INTEGRATION

The FYRLYT FYRFLY 640 thermal imaging camera is designed to integrate seamlessly into all aircraft avionics systems and displays that accept an analogue PAL/NTSC input.

RECOMMENDED CABLING & CONNECTIONS

To ensure optimal signal quality and reliability, it is recommended to use RG-179 75 ohm coaxial cables. Depending on the aircraft its possible that you will have ground loop noise in the video signal. Its good practice to use a ground loop isolator on the video input. Ground loop noise will appear as a wave through the video that is more or less constant.

There is also the possibility of radio interference from the communication system. This usually only occurs when transmitting. To mitigate this possibility try to run all connections behind a ground plane and always pass antenna cables at a 90 degree angle.

FYRFLY COMPATIBILITY WITH PFD & MFDS

The FYRFLY 640 can be integrated with all popular displays that accept an analogue PAL/NTSC input.

INTEGRATION WITH EXTERNAL MONITORS

The FYRFLY 640 can also be integrated with external monitors that allow an external PAL analogue signal.

CONSIDERATIONS

Ensure all wiring and connections comply with relevant aviation standards and the aircraft's electrical system specifications. Properly secure all cables to prevent interference with flight controls or other critical systems. Consult the aircraft and avionics system documentation for specific integration instructions and limitations. Conduct thorough post-installation testing to verify proper functionality and signal integrity. The FYRFLY 640's flexible integration options empower pilots to incorporate this valuable thermal imaging tool into their existing cockpit configurations, enhancing situational awareness and safety in challenging flight conditions.

END



WWW.FYRLYT.COM | MADE IN AUSTRALIA